

**1** PLACE THE CRADLE HALVES IN POSITION IN YOUR ROOM AND LAY THEM UPSIDE-DOWN ON A PROTECTIVE SURFACE SO THAT NO DAMAGE IS DONE TO YOUR FLOOR OR TO THE CRADLE. FASTEN THE TWO HALVES TOGETHER USING THE JOINER PLATE AND THE BOLTS PROVIDED.

**2** PLACE THE LEGS IN POSITION AND FASTEN THE CENTER LEG TO THE CRADLE USING THE BOLTS PROVIDED. FOR THE OUTER LEGS, DO NOT FULLY FASTEN THE BOLTS, LEAVING THE LEG SLIGHTLY LOOSE SO THAT THE CENTER STRETCHERS CAN BE INSTALLED.

**3** WITH HELP, INSTALL THE CENTER STRETCHERS BY USING THE BOLTS AND WASHERS PROVIDED. THEN FASTEN THE OUTER LEGS TIGHTLY, TO HOLD THE CENTER STRETCHERS IN PLACE.

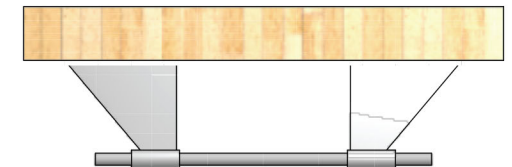
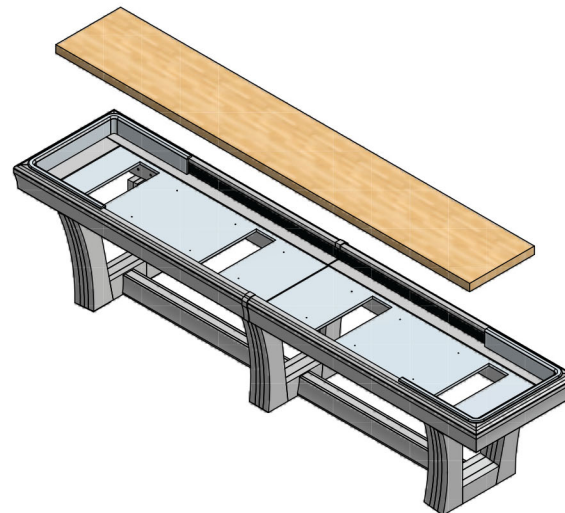
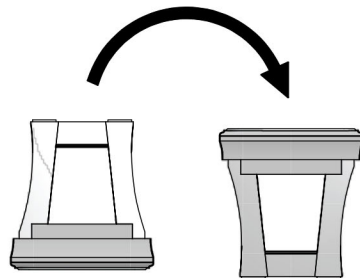

**4** WITH HELP, TURN THE TABLE UPSIDE-RIGHT. YOU ARE BASICALLY ROLLING IT OVER GENTLY.

**5** SET TWO SHUFFLEBOARD PUCKS ON EITHER END OF THE TABLE, THEN GET HELP TO LIFT THE PLAYFIELD INTO THE CRADLE, ON TOP OF THE PUCKS. FROM UNDERNEATH THE TABLE, LIFT THE PLAYFIELD AND REMOVE THE PUCKS. LEVEL THE TABLE USING THE ADJUSTABLE LEVELS ON THE LEG.

**6** ADJUST THE CLIMATIC ADJUSTERS SO THAT THE PLAYFIELD IS SLIGHTLY CONCAVE (THE MIDDLE OF THE TABLE BOWS DOWNWARD). USE THE OUTER AND INNER NUTS TO MAKE ADJUSTMENTS TO THE CONCAVITY OF THE PLAYFIELD.